

BK1

CENTRE PIN 60mm BASIN WASTE AND 1 1/4" BOTTLE TRAP ASSEMBLY

Installation and maintenance instructions

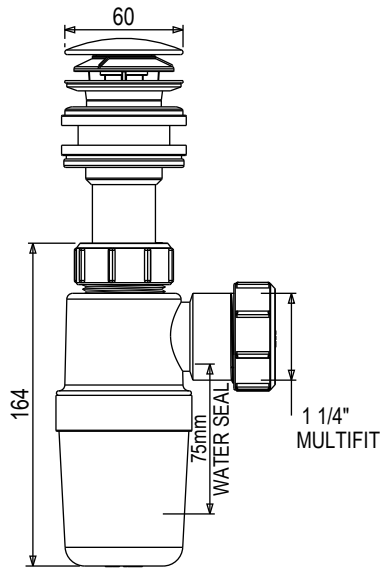

Installation instructions for CWP60-SSP: Spring loaded centre pin basin waste (Sub-assembly)

FIXING INSTRUCTIONS: DRY FIX. NO SEALANT-REQUIRED.

INSTALLATION WITH SPACER ON A WASH-HAND BASIN (WHB) WITHOUT OVERFLOW

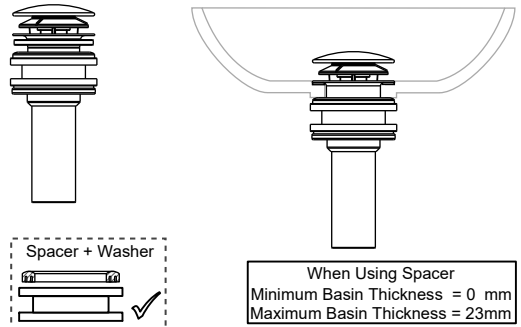

1. Place the Waste (3) with the white Washer (4) or apply **MACXSEAL** sealant into the waste hole in the WHB.
2. Drop the Ferrule (2) through the centre of the Waste (3).
3. Assemble the black washer (7) to the flange on the stalk (8), add the spacer (6) and then the silicon washer (5).
4. Position items 5,6,7,8 on the underside of the WHB at the waste outlet hole, and tighten (**No more than hand tight + 1/4 turn) the Ferrule (2) clockwise until the waste assembly is fixed to the WHB.
5. Finally, assemble the spring loaded plug assembly (1) by pushing the stem of the plug into the centre-pin ferrule (2).

INSTALLATION ON A WASH-HAND BASIN (WHB) WITH OVERFLOW.

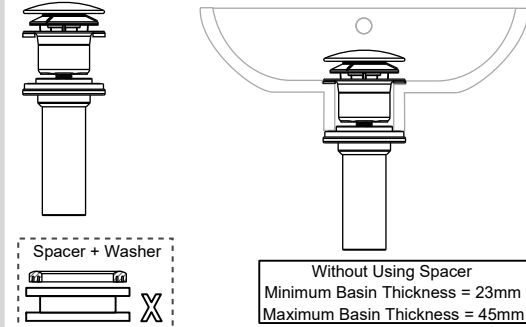

1. Place the Waste (3) with the white Washer (4) or apply **MACXSEAL** sealant into the waste hole in the WHB.
2. Drop the Ferrule (2) through the centre of the Waste (3).
3. Assemble the black washer (7) to the flange on the stalk (8)
4. Position items 7 and 8 on the underside of the WHB at the waste outlet hole, and tighten (**No more than hand tight + 1/4 turn) the Ferrule (2) clockwise until the waste assembly is fixed to the WHB.
5. Finally, assemble the spring loaded plug assembly (1) by pushing the stem of the plug into the centre-pin ferrule (2).

Components

Waste & Plug assembly

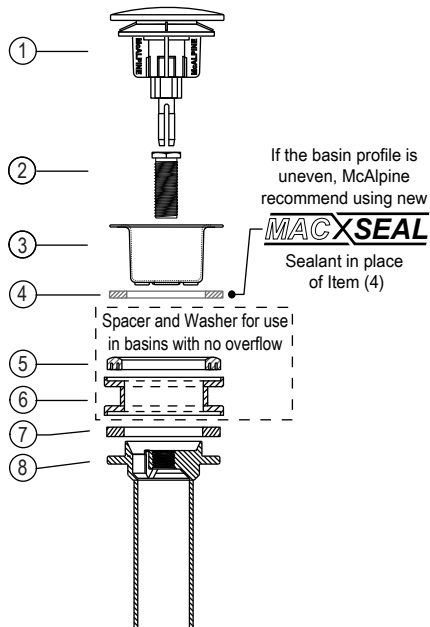

Bottle Trap assembly

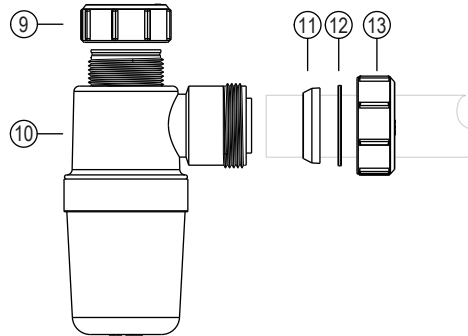

Installation instructions for Bottle Trap

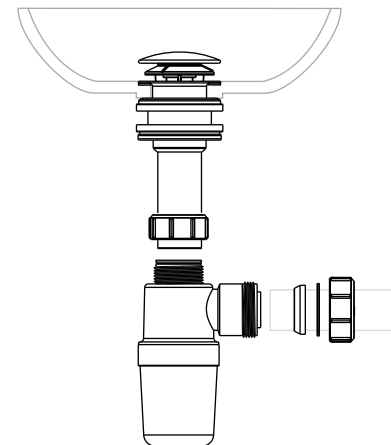

6. Remove Inlet Nut (9), from the trap body and assemble onto the waste assembly outlet stalk (8).
7. Assemble the Trap Body (10) onto the outlet stalk (8) and tighten the Inlet Nut (9) ****No more than hand tight + 1/4 turn.**
8. Assemble the Outlet Nut (13), Backup Washer (12) and Outlet seal (11) onto the outlet pipe and push into the outlet of the Trap Body (10). Push the Outlet Seal (11) and Backup Washer (12) forward into the trap body outlet, then tighten outlet nut (13). ****No more than hand tight + 1/4 turn.**

Complete Installation

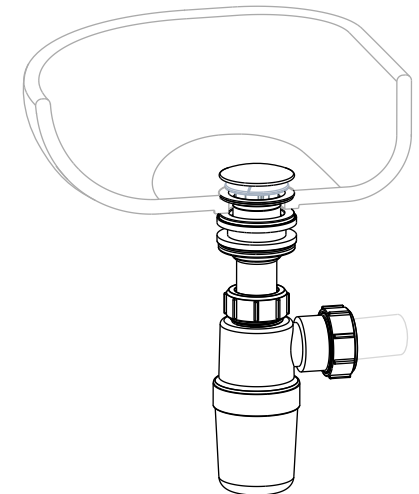

9. **Important** - Run water through completed installation, **Inspect all joints for leaks.**

Maintenance
Remove Plug Assembly (1) from waste, clean debris from waste. Flush water through trap periodically to clear debris from the trap body.